

ProservCrane Jib Cranes Designed to your Specifications

Motorized Base Mount



Compression Jib



Exclusive Head Design on all Full Rotation Jib Cranes

Removeable access plate permits convenient inspection and service of collector ring assembly, when installed.

Floating-action mast head assembly surrounds mast on sleeve principle. Mating surfaces are carried on upper and lower bearings, permitting head to rotate freely throughout 360 degrees.

Lower roller bearing design has row of continuous roller type bearings recessed into heavy machined ring welded to mast head assembly. Alemite fitting permits lubrication as required.

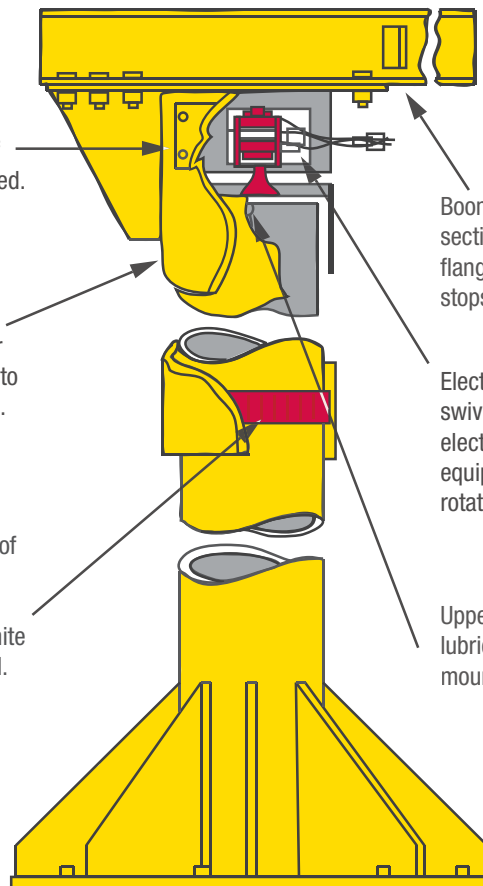

Boom construction of heavy section standard or wide flange beams with trolley stops located at both ends.

Electrical collector ring assembly or air swivel connection eliminates fouling of electrical or air supply lines to hoisting equipment and permits continuous rotation. (optional)

Upper bearing is lifetime lubricated sealed ball bearing mounted in machined seat.



Made in the USA

**Standard minimum features shown here.*

ProservCrane Jib Crane Options

- Power collector rings or air swivel
- Electric, air powered or hand-gearred rotation
- Rotation stops
- Position locks
- Tagline or festoon for supporting hoist, power cord or air line

- Multiple hoist & trolley options (Budgit, ACCO, CM, Coffing, Harrington, Ingersoll-Rand, R&M, Saturn, Shaw-Box and Yale.)
- Compression and tension jib fittings are available for customers wanting to build their own jib
- Unique or special applications requiring custom engineering are welcome

Base Mount

Available in standard models 1/4 Ton thru 5 Ton capacities with standard mast heights and boom reaches to 20 feet.

Larger sizes are available.

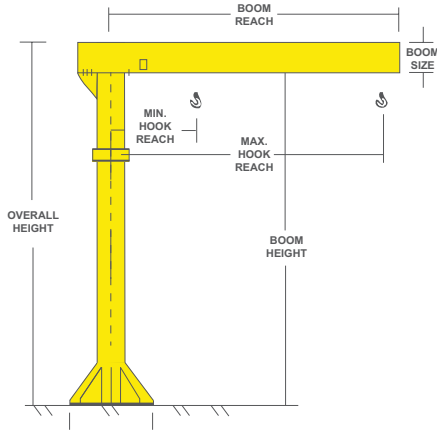

Foundation Mount

Foundation mounted jibs are anchored into a pipe sleeve that is placed into the slab when the foundation is poured.

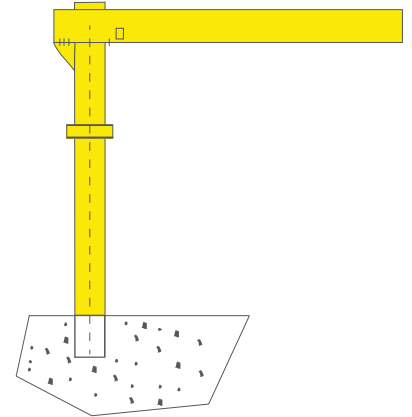

Column Mount

Column mounted jibs can either be mounted to an existing column or be supplied with the column.

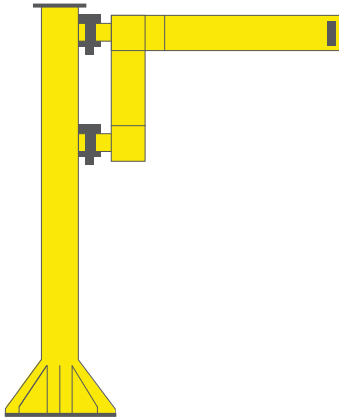

Rotating Column

Rotating columns are mounted by bearings on both the top and bottom of the column for a 360 degree rotation.

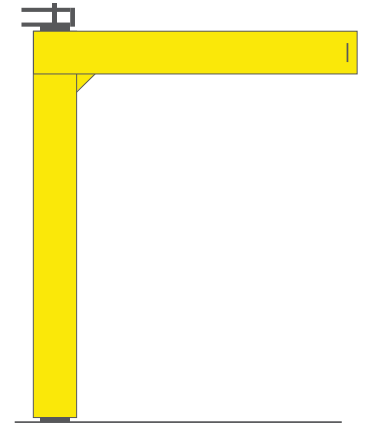

Wall Mount Full Compression Jib

Ideal for low headroom restrictions.

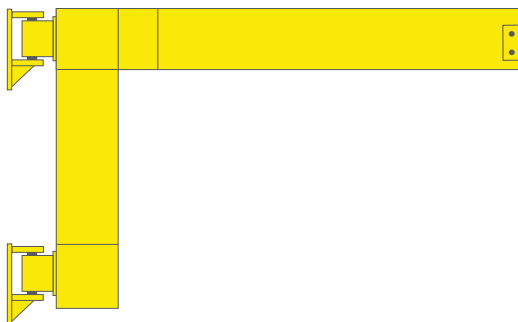

Wall Mount Tension Jib

Practical design where headroom is not a limiting factor.

